

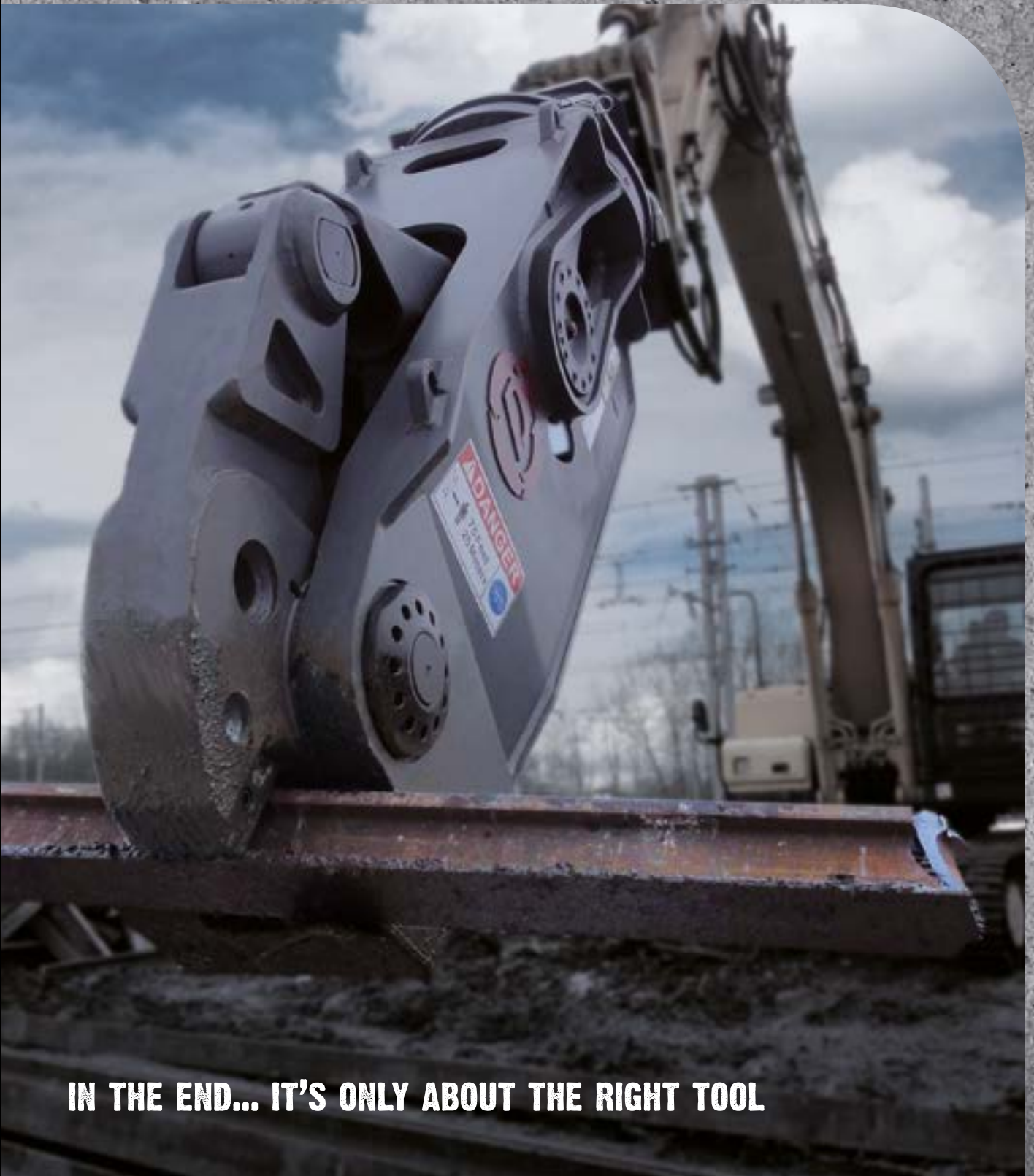

# DEMAREC RAIL CUTTER

RC-30, RC-30-S



IN THE END... IT'S ONLY ABOUT THE RIGHT TOOL

# DEMAREC RAIL CUTTER



The mobile DEMAREC Rail Cutter RC-30 is a special development for the controlled demolition of rail systems and for the scrap preparation of railway lines. All current Vignol rails (flat bottom rails) with a standard quality up to 900 N/mm<sup>2</sup> and a profile size „S7“ to „UIC 60“ can be cut. Vignol rails in

special qualities exceeding 900 N/mm<sup>2</sup> or with head hardening are excluded. The wear of the cutters highly depends on the quality of the rails. Cutting rails with an ordinary scrap shear is a risky task because of the flying scrap. With the Demarec Railcutter it is possible to cut safely and efficiently.

## Key features and benefits

- DemaPower-cylinder technique
- DemaSafety-System
- Extremely robust upper and lower jaw (Hituff)
- Overdimensioned pivot point
- Shear body made of high-strength fine grained steel
- Cutting blades are reversible - Tool Steel
- 360° heavy duty rotation (or without rotation)
- Filters in rotation circuit



A unique cylinder technique:  
20% more power and extremely fast cycle time!

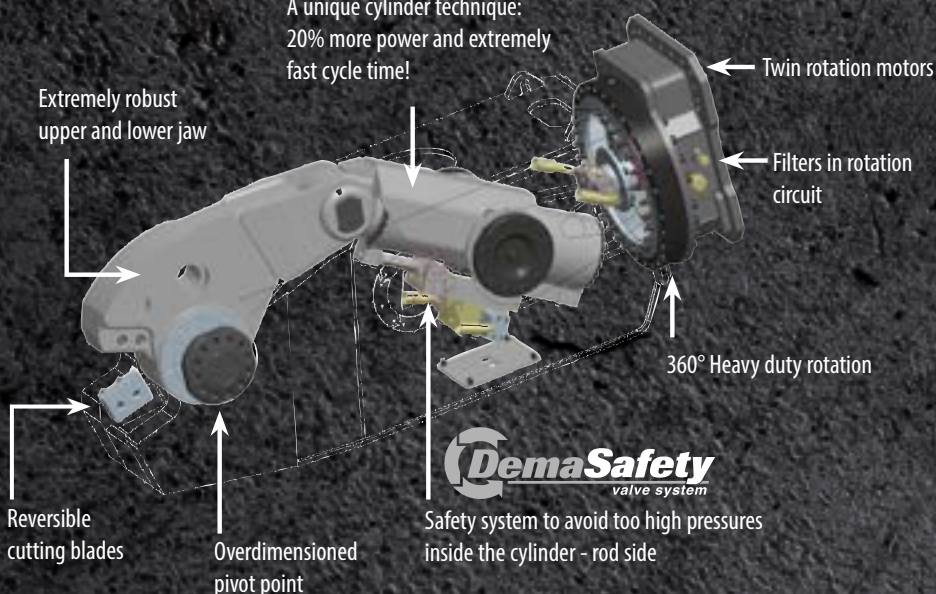

## Technical specifications

Type		RC-30	RC-30-S
Carrier weight*	ton	20 - 35	20 - 35
Weight (approx.)**	kg	2650	2300
Length	mm	2234	2040
Jaw opening	mm	224	224
Depth of jaw	mm	190	190
Opening/Closing Pmax	bar	320	320
Flow	l/min	150 - 250	150 - 250
Rotation Pmax	bar	140	-
Flow	l/min	40 - 60	-

\*Depending of capacity of carrier \*\*Weight excluding bracket

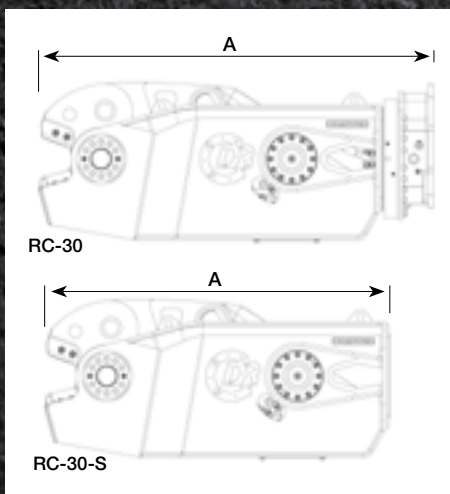

## TRENDSETTER IN DEMOLITION AND RECYCLING EQUIPMENT



Demolition and Recycling Equipment B.V., De Hork 32 - 5431 NS Cuijk - The Netherlands ☎ +31 (0)485 442300 - info@demarec.com